



The Soo Chimes

July 2026
Volume 58, Issue 7

[Discipleship / Worship](#)

[Service / Mission](#)

[Church Life](#)

[Social Links](#)

[Calendar](#)

Pastor's Message

Freedom Worth Guarding

Because many Americans have never known life without freedom, it can be easy to take our liberties for granted. The Israelites, however, knew the harsh reality of slavery. Yet even after God led them out of Egypt, they struggled to embrace their newfound freedom. Faced with uncertainty, they grew fearful and complained against Moses and Aaron, longing for the familiarity of their former bondage rather than trusting God's provision.

Their story feels surprisingly familiar. As Christians, we have been set free through a far greater deliverance. Our freedom was secured at a great cost through the life, death and resurrection of Jesus Christ. And yet, we sometimes drift back toward old habits, attitudes and patterns that once held us captive.

Scripture reminds us to stand firm in the freedom we have been given. As Paul writes in Galatians 5:1 (NKJV), "Stand fast therefore in the liberty by which Christ has made us free, and do not be entangled again with a yoke of bondage."

True freedom is not simply the absence of restraint. It is the opportunity to live fully in God's grace, walking in obedience, joy and purpose. This kind of freedom is worth celebrating, protecting and living out every day.

Pastor Mark



From The Trustees:

We hope everyone is enjoying our well-deserved summer weather! Summertime means we are about midway through our calendar year, which is a great time to review our personal church contributions. This year we decided to return to our weekly offering and expense reporting in the service bulletins as we did years ago. The bulletin reports might be made even clearer with some further explanation and context. You may have noticed some weeks with more robust offering totals than others. This is typically due to members paying their annual contribution in one lump sum and is not necessarily reflective of a typical offering week. We welcome contributions in whatever format works best for members and certainly do not want to discourage annual giving. It's just important to note that the *weekly* offering may at times seem a bit healthier than it is, especially during the first few months of the year.

Likewise, you may have noticed some weeks with larger expense totals. We were faced with some extra-large expenses this year, partially due to the harsh winter and extreme snowfall. We also incurred some extra kitchen repair expenses recently.

In other contribution news - Nancy brought to our attention that the 2026 charitable giving non-itemized deductions have been increased to \$1000 for an individual and \$2000 for couples filing jointly. To qualify, the gift must be a direct cash/check contribution to a qualified public charity or non-profit organization, such as our church.

We are indeed facing a budget shortfall for 2026. If you are able to give a little extra this year, your consideration would be greatly appreciated. The loss of several wonderful church families who have left our area is felt in more ways than one. We would love to see our congregation grow and flourish! We encourage everyone to welcome friends, neighbors, and community members to attend a service and see what FUPC has to offer!

Discipleship / Worship

July

- **July 1**
Joshua 15–16
Psalms 149:1–9
Proverbs 18:8
- **July 2**
Joshua 17–18
Psalms 150:1–6
Proverbs 18:9–10
- **July 3**
Joshua 19–20
Psalms 1:1–6
Proverbs 18:11–12
- **July 4**
Joshua 21–22
Psalms 2:1–12
Proverbs 18:13
- **July 5**
Joshua 23–24
Psalms 3:1–8
Proverbs 18:14–15
- **July 6**
Judges 1–3
Psalms 4:1–8
Proverbs 18:16–18
- **July 7**
Judges 4–5
Psalms 5:1–12
Proverbs 18:19
- **July 8**
Judges 6–8
Psalms 6:1–10
Proverbs 18:20–21
- **July 9**
Judges 9–10
Psalms 7:1–17
Proverbs 18:22
- **July 10**
Judges 11–13
Psalms 8:1–9
Proverbs 18:23–24
- **July 11**
Judges 14–16
Psalms 9:1–12
Proverbs 19:1–3
- **July 12**
Judges 17–19
Psalms 9:13–20
Proverbs 19:4–5
- **July 13**
Judges 20–21
Psalms 10:1–15
Proverbs 19:6–7
- **July 14**
Ruth 1–4
Psalms 10:16–18
Proverbs 19:8–9
- **July 15**
1 Samuel 1–3
Psalms 11:1–7
Proverbs 19:10–12
- **July 16**
1 Samuel 4–7
Psalms 12:1–8
Proverbs 19:13–14
- **July 17**
1 Samuel 8–12
Psalms 13:1–6
Proverbs 19:15–16
- **July 18**
1 Samuel 13–14
Psalms 14:1–7
Proverbs 19:17
- **July 19**
1 Samuel 15–16
Psalms 15:1–5
Proverbs 19:18–19
- **July 20**
1 Samuel 17–18
Psalms 16:1–11
Proverbs 19:20–21
- **July 21**
1 Samuel 19–21
Psalms 17:1–15
Proverbs 19:22–23
- **July 22**
1 Samuel 22–24
Psalms 18:1–15
Proverbs 19:24–25
- **July 23**
1 Samuel 25–27
Psalms 18:16–36
Proverbs 19:26
- **July 24**
1 Samuel 28–31
Psalms 18:37–50
Proverbs 19:27–29
- **July 25**
2 Samuel 1–3
Psalms 19:1–4
Proverbs 20:1
- **July 26**
2 Samuel 4–7
Psalms 20:1–9
Proverbs 20:2–3
- **July 27**
2 Samuel 8–11
Psalms 21:1–13
Proverbs 20:4–6
- **July 28**
2 Samuel 12–13
Psalms 22:1–18
Proverbs 20:7
- **July 29**
2 Samuel 14–16
Psalms 22:19–31
Proverbs 20:8–10
- **July 30**
2 Samuel 17–19
Psalms 23:1–6
Proverbs 20:11
- **July 31**
2 Samuel 20–22
Psalms 24:1–10
Proverbs 20:12





Church Life

Birthdays

Date Names

| | | | | | |
|-----|-------------------|------|-----------------|------|----------------|
| - | | | | | |
| 7/1 | Coby Piche | 7/9 | Ginger Stratton | 7/17 | William |
| | Krempel | | | | |
| 7/3 | Dolores Sundstrom | 7/9 | Suzanne Worsham | 7/18 | Callie Mackie |
| 7/4 | Sawyer Howson | 7/10 | Julie Martin | 7/19 | Steven Bernier |
| 7/5 | Addison Gerrie | 7/11 | Brady Howson | 7/20 | Marsha Cross |
| 7/5 | Taylor Worsham | 7/13 | Nicholas Gerrie | 7/22 | Kamryn |
| | Corbiere | | | | |
| 7/9 | Kacie Corbiere | 7/14 | Cathy Agar | 7/28 | Doug |
| | Lundstrom | | | | |

HAPPY BIRTHDAY!

Anniversaries

Date Names

| | |
|------|----------------------------|
| 7/3 | Jim & Suzanne Worsham |
| 7/5 | Theodore & Connie Lawrence |
| 7/26 | Steve & Kathy Gerrish |

HAPPY ANNIVERSARY!



PW News:

Our annual rummage sale will be held on August 1st and plans are underway. Start cleaning your attics, basements, garages and cupboards of your overflow and unused items. If you are willing to help in any way, please contact Doris Boogerd at 616-901-4299.

Recipe

Jiffy Corn Casserole.

What you will need:

- 1 (15 oz) can whole kernel corn, **drained**
- 1 (15 oz) can creamed corn
- 1 (8.5 oz) box Jiffy Corn Muffin Mix
- 1 cup (8oz) sour cream
- 8 Tbsp (1 stick) melted butter (unsalted)
- 2 large eggs
- Cooking spray

Instructions:

Preheat your oven to 350 degrees F. Lightly grease a baking dish. (8x8, 9x9 or a pie pan). In a large bowl, whisk eggs and sour cream until smooth. Stir in melted butter, both cans of corn and then the Jiffy mix. Stir until just combined. Pour into prepared dish. Bake 45 - 55 minutes until center is set and top is golden. Let cool 10 minutes before serving.

Serves: 8 / Prep: 10 min / Bake: 45 - 55 min

Kids' Page

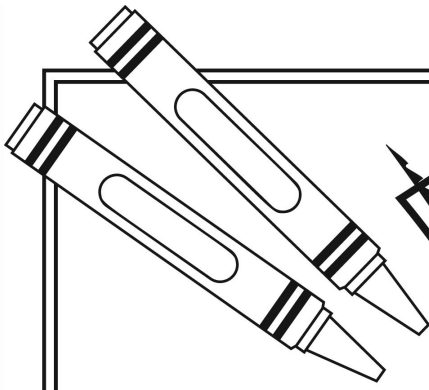





PUZZLE

"IN DEPENDENCE" DAY!

Always live "in dependence" on God.

Directions: Use the vowel code to complete Psalm 16:8, NIV.

| | | | | |
|--|--|--|---|--|
| A=  | E=  | I=  | O=  | U=  |
|--|--|--|---|--|

k _ _ p my _ y _ s
 I w _ y s _ n th _ L _ RD.
 W _ th h _ m _ t my
 r _ ght h _ nd,
 w _ ll n _ t b _ sh _ k _ n.
 Ps _ Im 16:8, N _ V

Answer: I keep my eyes always on the LORD. With him at my right hand, I will not be shaken. Psalm 16:8, NIV

[View Our Church Calendar](#)
[Visit Our Website](#)

